

Heavy Vehicle Parking

Council has heavy vehicle parking controls in place to protect the safety of road users, pedestrians and residents. Parking or storage of heavy vehicles is to be undertaken in such a manner that it does not cause nuisance or disturbance to the community.

The laws that apply to the parking of heavy vehicles within the Ipswich City Council area are:

- for stopping on roads - *Transport Operations (Road Use Management – Road Rules) Regulation 2009 (TORUM)*
- for parking on residential properties – Council's Local Laws

HEAVY VEHICLES STOPPING ON ROADS

TORUM defines a heavy vehicle as any vehicle with a Gross Vehicle Mass (GVM) of 4.5 tonnes or more. A heavy vehicle generally must not stop on the road in a built-up area for longer than one hour.

For further information *TORUM* can be viewed at www.legislation.qld.gov.au.

HEAVY VEHICLES PARKING ON RESIDENTIAL PROPERTIES

Council's Local Law definition of a heavy vehicle captures a large range of vehicles, including adjunct vehicles.

Heavy Vehicle means any of the following:

- a vehicle or combination of vehicles that has a GVM of more than 4.5 tonnes, or has a total length in excess of 7.5 metres;
- a trailer or semi trailer standing alone which has a GVM of 3 or more tonnes or has a length exceeding 5 metres;
- any vehicle of whatever size equipped to carry, by whatever means, a motor vehicle;
- a tractor;
- any vessel whose length exceeds 9 metres; and
- any other vehicle or equipment which is consistent with those vehicles listed above.

Adjunct Vehicle means any of the following:

- any trailer designed or adapted for the carriage of goods with a carrying capacity in excess of 2 tonne tare including the trailer of an articulated vehicle;
- any trailer designed or adapted for earthmoving or road making purposes, including a vehicle or equipment designed or adapted for excavating materials or equipment such as rollers, compressors or the like designed or adapted to be drawn behind a heavy vehicle;
- any trailer containing a refrigeration unit;
- any earthmoving equipment or vehicle which is capable of being transported on the tray of a heavy vehicle; and
- any other trailer or equipment which is consistent with those trailers or equipment listed above.

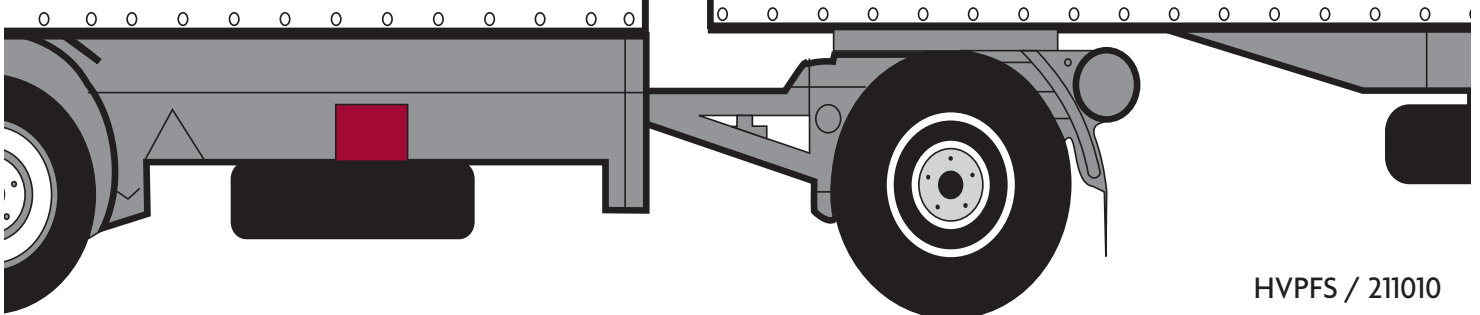

HVPFS / 211010

For a copy of Council's Local laws visit www.ipswich.qld.gov.au under 'About Council', 'Corporate Publications'.

For further information contact

Ipswich City Council

Phone: (07) 3810 6666

www.ipswich.qld.gov.au

HEAVY VEHICLE PARKING PERMITS

Under Council's Local Laws you can apply for a heavy vehicle parking permit to park a single heavy vehicle on a residential property.

Such an application is assessed against the criteria contained within the Local Law on a case by case basis. Residents are encouraged to contact Council to discuss the suitability of a proposed site where they are unsure if the proposal can meet the criteria of the Local Law.

Note: Parking of more than one heavy vehicle on a residential property constitutes a General Industry (Truck Depot) pursuant to the Ipswich Planning Scheme and would require a planning application to be made to Council. Such a use within a residential area is generally unlikely to be supported due to the impacts on the surrounding area.

An application form for a Heavy Vehicle Parking Permit is available on Council's website under 'Residents', 'Laws & Regulations', 'Parking' or by contacting Council on (07) 3810 6666.

If a permit is granted it is valid for the financial year and an application for renewal is required each financial year thereafter.

Non-compliance with Council's Local Laws or a condition of the permit may result in a Penalty Infringement Notice (fine) being issued to the owner or driver of the heavy vehicle.

COUNCIL'S GUIDELINE TO HELP REGULATE HEAVY VEHICLE PARKING IN IPSWICH

Council has developed Implementation Guideline 16 to assist customers in determining whether a Heavy Vehicle Parking Permit is applicable to their circumstances.

The guideline designates two types of preferred heavy vehicle parking areas and provides maps illustrating these areas.

- Category A areas outline where no permit is required if parking a single heavy vehicle (unless there is a concentration of existing residential uses within 100m).
- Category B areas outline the preferred heavy vehicle parking areas but a permit is still required.

Implementation Guideline 16 is part of the Ipswich Planning Scheme and can be viewed at www.ipswich.qld.gov.au via 'PD Online' under the 'Online Services' section.



HVPFS / 211010